

DCP-330C
DCP-540CN

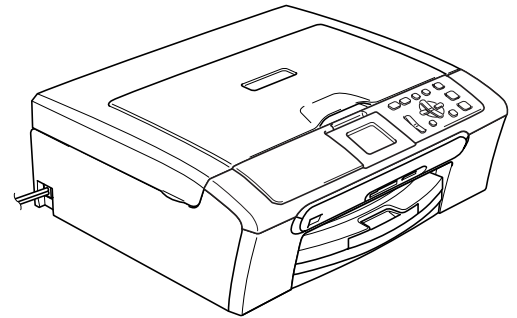

Before you can use the machine, you must set up the hardware and install the software.
Please read this Quick Setup Guide for the correct setup procedure and installation instructions.

STEP 1

Setting Up the Machine







STEP 2

Installing the Driver & Software

Setup is Complete!

Keep this Quick Setup Guide, the User's Guide and the supplied CD-ROM in a convenient place for quick and easy reference at all times.

Symbols used in this guide

 Warning	 Caution	 Improper Setup
Warnings tell you what to do to prevent possible personal injury.	Cautions specify procedures you must follow or avoid to prevent possible damage to the machine or other objects.	Improper Setup icons alert you to devices and operations that are not compatible with the machine.
 Note	 User's Guide, Software User's Guide or Network User's Guide	
Notes tell you how you should respond to a situation that may arise or give tips about how the current operation works with other features.	Indicates reference to the User's Guide, Software User's Guide or Network User's Guide we have supplied.	

Getting Started

Carton components	2
Control panel	3

STEP1 – Setting Up the Machine

Removing the protective parts	4
Loading paper	4
Connecting the power cord	6
Installing the ink cartridges	6
Print quality check	8
Choosing your language (Canada only)	9
Setting the LCD contrast	10
Setting the date and time	10

STEP2 – Installing the Driver & Software

Windows®

For USB Interface Users (For Windows® 98/98SE/Me/2000 Professional/XP/XP Professional x64 Edition)	14
For Network Interface Users (DCP-540CN only) (For Windows® 98/98SE/Me/2000 Professional/XP/XP Professional x64 Edition)	17

Macintosh®

For USB Interface Users (For Mac OS® X 10.2.4 or greater)	21
For Network Interface Users (DCP-540CN only) (For Mac OS® X 10.2.4 or greater)	24

For Network Users

BRAdmin Professional configuration utility (For Windows® users)	27
Installing the BRAdmin Professional configuration utility	27
Setting your IP address, Subnet Mask and Gateway using BRAdmin Professional	27
BRAdmin Light configuration utility (For Mac OS® X users)	28
Setting your IP address, Subnet Mask and Gateway using BRAdmin Light	28



Consumables

Replacement consumables	29
Ink cartridge	29

Carton components

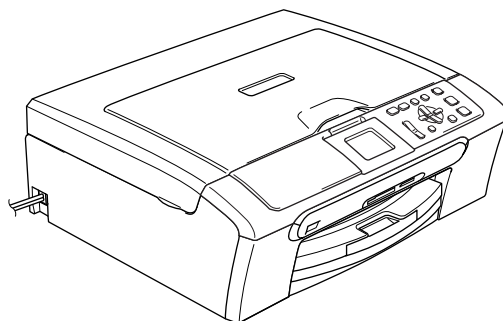
Carton components may vary from one country to another.
Save all packing materials and the carton in case for any reason you must ship your machine.

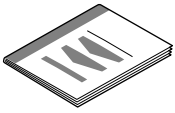

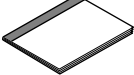
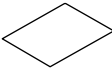
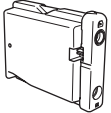
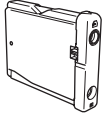
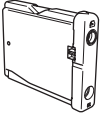
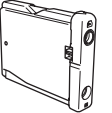
 Quick Setup Guide	 CD-ROM	 User's Guide	 Accessory Order Form
 Black (LC51BK)	 Yellow (LC51Y)	 Cyan (LC51C)	 Magenta (LC51M)
Ink Cartridges			

An interface cable is not a standard accessory. You need to purchase the proper interface cable for the interface you want to use (USB or network).

USB cable

- Please make sure you use a USB 2.0 cable that is no longer than 6 feet long (2 meters).
- Your machine has a USB interface that is compatible with the USB 2.0 specification. This interface is also compatible with Hi-Speed USB 2.0; however, maximum data transfer rate will be 12 Mbits/s. The machine can also be connected to a computer that has a USB 1.1 interface.
- DO NOT connect the interface cable at this time.
Connecting the interface cable is done during the software installation process.
When you use a USB cable, make sure you connect it to the USB port of your computer and not to a USB port on a keyboard or a non-powered USB hub.

Network cable (DCP-540CN only)

- Use a straight-through Category5 (or greater) twisted-pair cable for 10BASE-T or 100BASE-TX Fast Ethernet Network.

Control panel

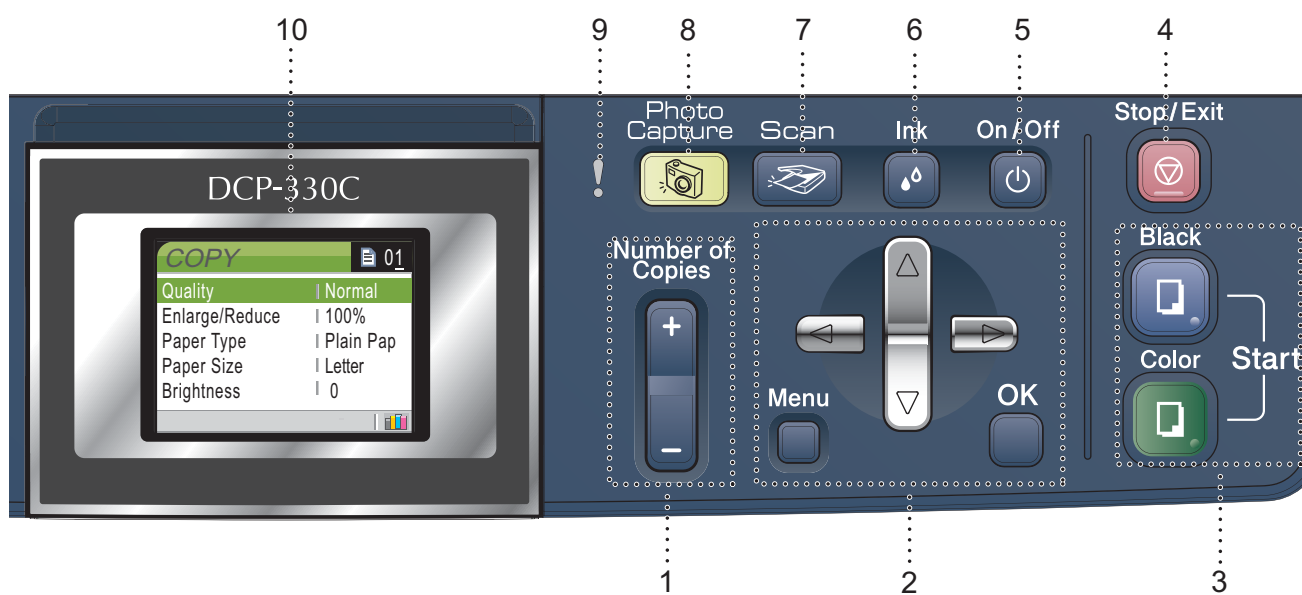

- 1 Number of Copies key
- 2 Menu keys
- 3 Start keys
- 4 Stop/Exit key
- 5 On/Off key
- 6 Ink key
- 7 Scan key
- 8 PhotoCapture key
- 9 Warning LED
- 10 LCD (Liquid Crystal Display)

 For the details of the control panel, see *Control panel overview* in Chapter 1 of the User's Guide.

■ Illustrations in this Quick Setup Guide are based on DCP-330C.

1 Removing the protective parts

- 1 Remove the protective tape and film covering the scanner glass.
- 2 Remove the foam bag containing the ink cartridges from on top of the paper tray.

⊘ Improper Setup

DO NOT connect the interface cable.
Connecting the interface cable is done during the software installation process.

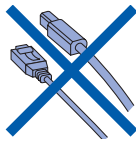

2 Loading paper



You can load up to 100 sheets of 20 lb (80 g/m²) paper.
For details, see *Acceptable paper and other media* in Chapter 2 of the User's Guide.

- 1 Pull the paper tray completely out of the machine and lift the output paper tray cover (1).

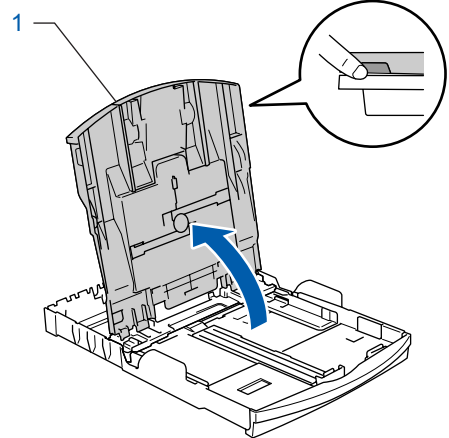
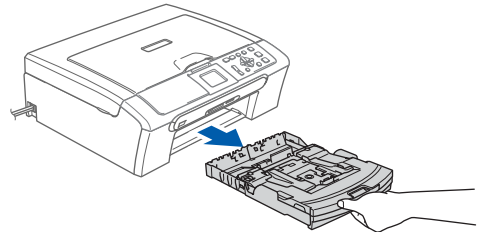

- 2 Press and slide the paper side guides (1) and paper length guide (2) to fit the paper size.

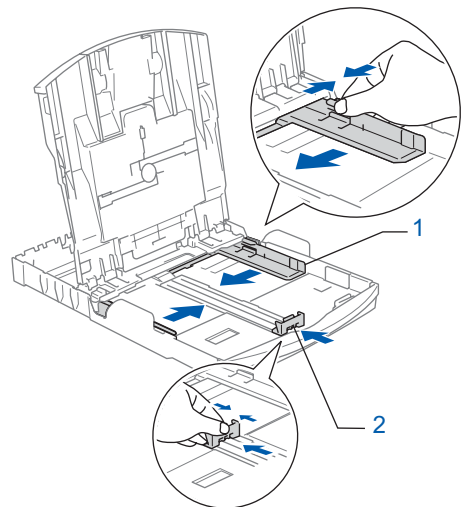

Setting Up the Machine

- 3** Fan the stack of paper well to avoid paper jams and misfeeds.

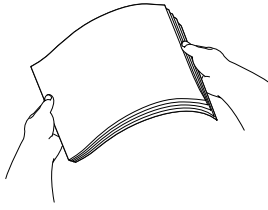

- 4** Gently put the paper into the paper tray print side down and top edge first. Check that the paper is flat in the tray.

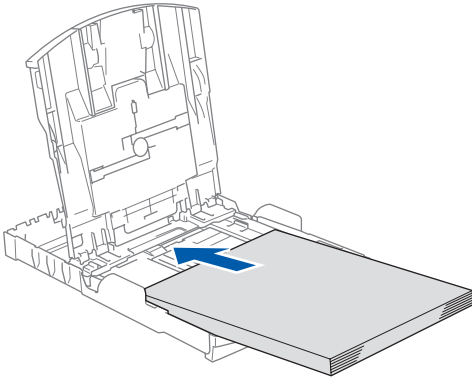

Note

When you use Legal size paper, press and hold the universal guide release button as you slide out the front of the paper tray.

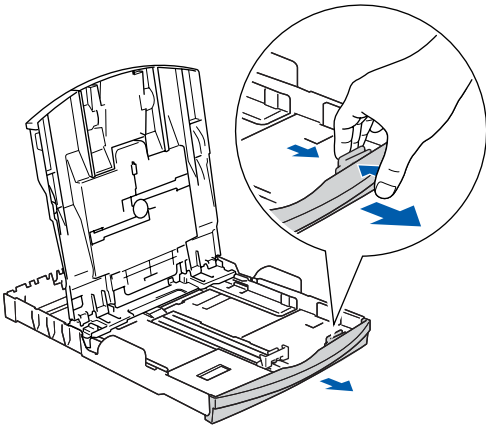

- 5** Gently adjust the paper side guides with both hands to fit the paper. Make sure that the paper side guides and paper length guide touch the edges of the paper.

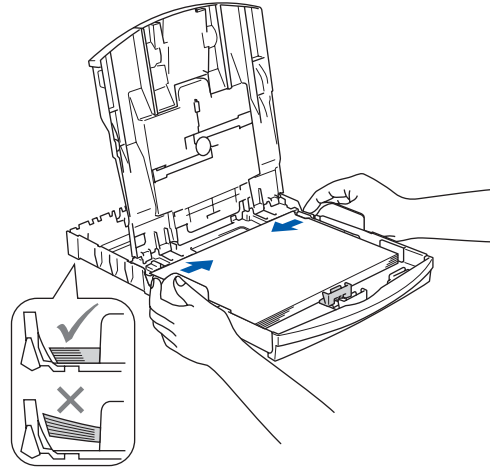

Note

Be careful that you do not push the paper in too far; it may lift at the back of the tray and cause paper feed problems.

- 6** Close the output paper tray cover.

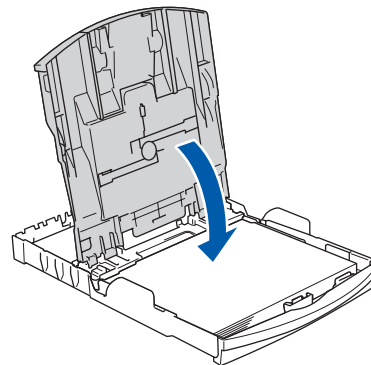

- 7** Slowly push the paper tray completely into the machine.

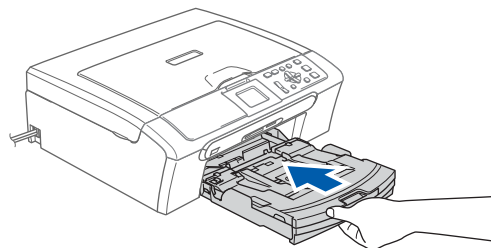

- 8** While holding the paper tray in place, pull out the paper support (①) until it clicks, and then unfold the paper support flap (②).

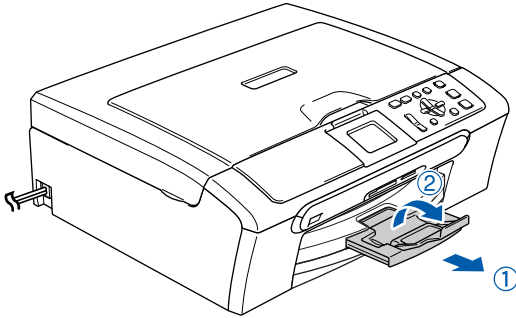

Note
Do not use the paper support flap for Legal paper.

Note
You can use the photo bypass tray is located on the top of the paper tray to print on photo 4×6 in. (10×15 cm) and photo L size paper. For details, see Loading photo paper in Chapter 2 of the User's Guide.

3 Connecting the power cord

- 1** Connect the power cord.

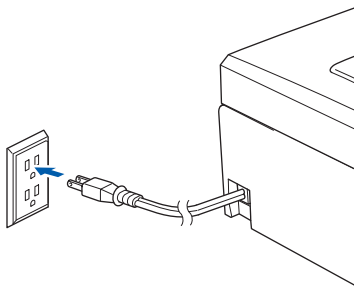

⊘ Improper Setup

DO NOT connect the interface cable.
Connecting the interface cable is done during the software installation process.

Note
The control panel warning LED will stay on until you have installed the ink cartridges.

4 Installing the ink cartridges

⚠ Warning

If ink gets in your eyes, wash them out with water at once, and if irritation occurs consult a doctor.

- 1** Make sure that the power is turned on. The LCD shows:



- 2** Open the ink cartridge cover (1).

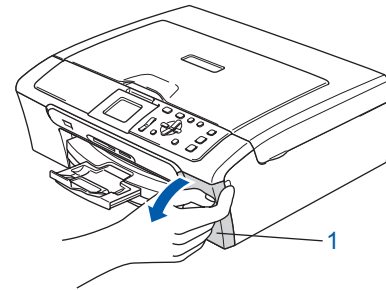

- 3** Pull all the lock release levers down and remove the yellow protective part (1).

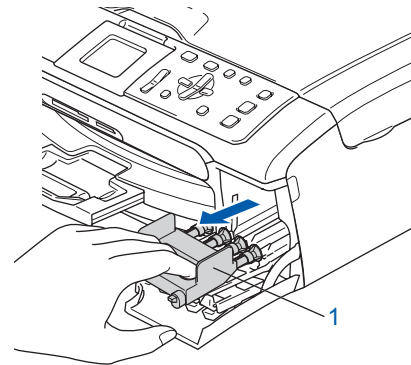
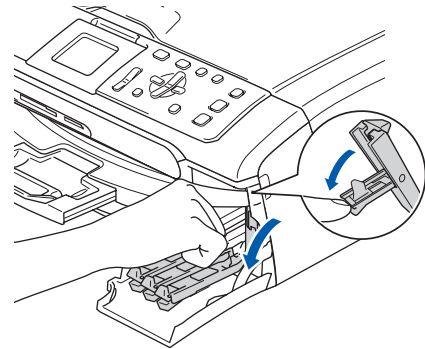

Note
Do not throw away the yellow protective part. You will need it if you transport the machine.

- 4** Take out the ink cartridge.

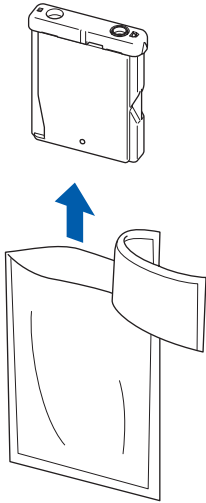

- 5** Carefully remove the protective yellow cap (1).

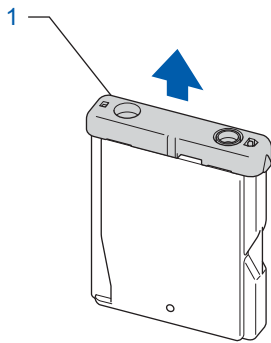

⊘ Improper Setup

DO NOT touch the area shown in the illustration below.

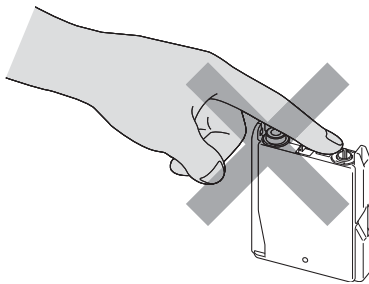

📄 Note

If the protective yellow cap comes off when you open the bag, the cartridge will not be damaged.

- 6** Install each ink cartridge in the direction of the arrow on the label. Take care to match the color of the lock release lever (1) with the cartridge color (2), as shown in the diagram below.

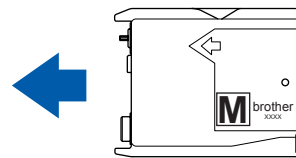
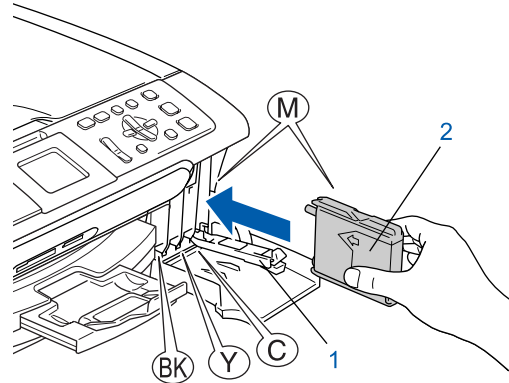

- 7** Lift each lock release lever and gently push it until it clicks, and then close the ink cartridge cover.

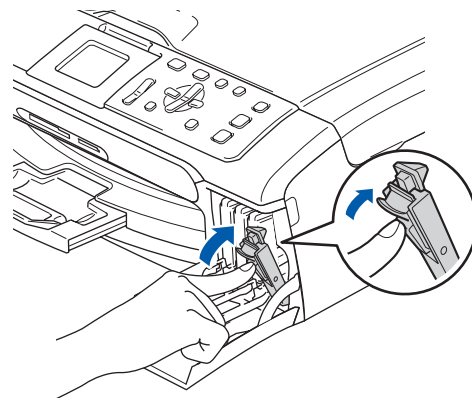

📄 Note

If the LCD prompts you to re-insert the ink cartridge correctly, after you install the ink cartridges, check that the ink cartridges are installed properly.

The machine will clean the ink tube system for use for the first time. This process will occur only once, the first time ink cartridges are installed. The cleaning process will last approximately four minutes. The LCD shows:

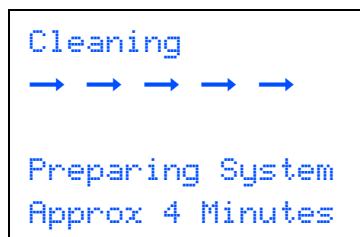

! Caution

- **DO NOT** take out ink cartridges if you do not need to replace them. If you do so, it may reduce the ink quantity and the machine will not know the quantity of ink left in the cartridge.
- **DO NOT** shake the ink cartridges. If ink stains your skin or clothing, wash with soap or detergent at once.
- **DO NOT** repeatedly insert and remove the cartridges. If you do so, ink may seep out of the cartridge.
- If you mix the colors by installing an ink cartridge in the wrong position, clean the print head several times after correcting the cartridge installation. (See *Cleaning the print head in Appendix B of the User's Guide.*)
- Once you open an ink cartridge, install it in the machine and use it up within six months of installation. Use unopened ink cartridges by the expiration date written on the cartridge package.
- **DO NOT** dismantle or tamper with the ink cartridge, this can cause the ink to leak out of the cartridge.
- Brother strongly recommends that you do not refill the ink cartridges provided with your machine. We also strongly recommend that you continue to use only Genuine Brother Brand replacement ink cartridges. Using or attempting to use potentially incompatible inks and/or cartridges in your machine may cause damage to the machine itself and/or it may result in unsatisfactory print quality. Our warranty coverage does not apply to any problem that was caused by the use of unauthorized third party ink and/or cartridges. To protect your investment and guarantee your print quality please continue to replace consumed ink cartridges with only Genuine Brother Branded Supplies.

5 Print quality check

- 1 After the cleaning cycle is finished, the LCD shows:

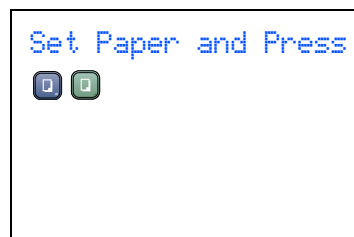

- 2 Make sure paper is loaded in the paper tray. Press **Color Start**. The machine starts printing the Print Quality Check Sheet (only during initial ink cartridge installation).
- 3 Check the quality of the four color blocks on the sheet.
(black/ yellow/ cyan/ magenta)

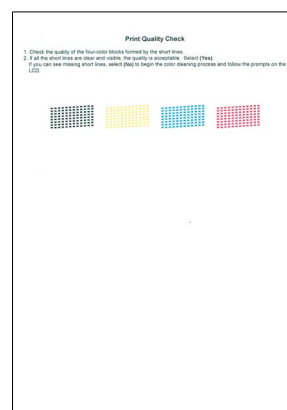

⊘ Improper Setup

Avoid touching the printed surface of the paper immediately after printing, the surface may not be completely dry and may stain your fingers.

4 The LCD shows:

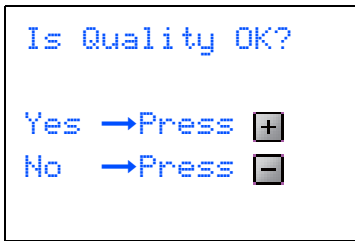

5 Do one of the following:

- If all lines are clear and visible, press (Yes) to finish the quality check.
- If you can see missing short lines, press (No) and go to step **6**.

OK

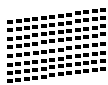

Poor



6 The LCD asks you if the print quality is OK for black and color. Press (Yes) or (No).

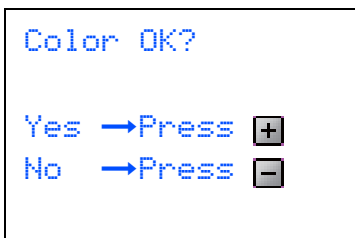
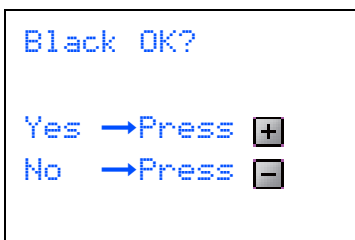

After pressing (Yes) or (No) for both black and color, the LCD shows:

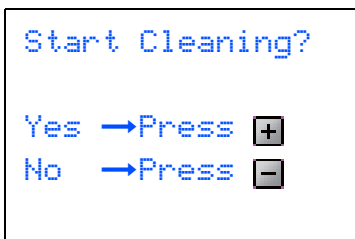

7 Press (Yes), the machine will then start cleaning the colors.

8 After cleaning is finished, press **Color Start**. The machine starts printing the Print Quality Check Sheet again and goes back to step **3**.

6 Choosing your language (Canada only)

1 Press **Menu**.

2 Press or to choose **Initial Setup**. Press **OK**.

3 Press or to choose **Local Language**. Press **OK**.

4 Press or to choose your language (**English** or **French**), and then press **OK**.



5 Press **Stop/Exit**.

7 Setting the LCD contrast

You can adjust the LCD contrast for a sharper and more vivid display. If you are having difficulty reading the LCD, try changing the contrast setting.

- 1 Press **Menu**.
- 2 Press **▲** or **▼** to choose `General Setup`. Press **OK**.
- 3 Press **▲** or **▼** to choose `LCD Settings`. Press **OK**.
- 4 Press **▲** or **▼** to choose `LCD Contrast`. Press **OK**.
- 5 Press **▲** or **▼** to choose `Light`, `Med` or `Dark`. Press **OK**.
- 6 Press **Stop/Exit**.



Note

You can also adjust the angle of the LCD display by lifting it.

8 Setting the date and time

Setting the date and time allows the machine to clean the print head regularly and maintain optimum print quality. It also allows the machine to name files created when using the Scan to Card feature.

- 1 Press **Menu**.
- 2 Press **▲** or **▼** to choose `Initial Setup`, and then press **OK**.
- 3 Press **▲** or **▼** to choose `Date/Time`, and then press **OK**.
- 4 Press **▲** repeatedly to enter the last two digits of the year, and then press **OK**.

```
Date/Time
Year:20
07
```

(e.g. Enter **07** for 2007.)

- 5 Press **▲** repeatedly to enter the two digits for the month, and then press **OK**.

```
Date/Time
Month:
01
```

(e.g. Enter **01** for January.)

- 6 Press **▲** repeatedly to enter the two digits for the day, and then press **OK**.

```
Date/Time
Day:
01
```

(e.g. Enter **01** for the first day of the month.)

- 7** Press ▲ repeatedly to enter the two digits for the hour in 24-hour format, and then press ► to enter the minutes.

```
Date/Time
Time:
15:XX
```

(e.g. Enter **1 5** for 3:00 P.M.)

- 8** Press ▲ repeatedly to enter the two digits for the minute, and then press **OK**.

```
Date/Time
Time:
15:25
```

(e.g. Enter **1 5, 2 5** for 3:25 P.M.)



Note

You can increase or decrease the number rapidly by holding down ▲ or ▼.

- 9** Press **Stop/Exit**.



Note

If you want to start again, press **Stop/Exit** to go back to step **1**.



To confirm the current date and time, print out the Users Settings Report. (See Printing reports in Chapter 1 of the User's Guide.)

Now go to

Go to *Supplied CD-ROM 'MFL-Pro Suite'* on the next page to install the drivers.

Supplied CD-ROM 'MFL-Pro Suite'

Windows®



Install MFL-Pro Suite

You can install the MFL-Pro Suite software and multifunction drivers.



Install Other Drivers or Utilities

You can install additional MFL-Pro Suite software utilities, install without PaperPort® SE, or install the printer driver only.



User's Guide

View the Software User's Guide and Network User's Guide (DCP-540CN only) in HTML format. The Software User's Guide and Network User's Guide include instructions for features available when connected to a computer. (eg. Printing, scanning and networking details)



On-Line Registration

You will be pointed to the Brother Product Registration Web page for quick registration of your machine.



Brother Support

View contact information for Brother Customer Service and how to find a Brother Authorized Service Center.



Repair MFL-Pro Suite (USB only)

If an error occurred during the installation of the MFL-Pro Suite, use this selection to automatically repair and re-install the MFL-Pro Suite.



Note

MFL-Pro Suite includes the Printer Driver, Scanner Driver, Brother ControlCenter3, ScanSoft® PaperPort® SE with OCR and True Type® fonts.

PaperPort® SE is a document management application for scanning and viewing documents.

Macintosh®

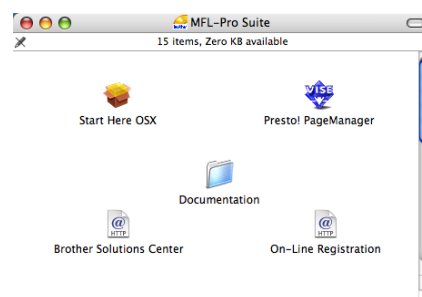

Start Here OSX

You can install the MFL-Pro Suite that includes the printer driver, scanner driver and the Brother ControlCenter2 for Mac OS® 10.2.4 or greater.



Presto! PageManager

You can also install Presto!® PageManager® to add OCR capability to the Brother ControlCenter2 and easily scan, share and organize photos and documents.



Documentation

View the Software User's Guide and Network User's Guide (DCP-540CN only) in HTML format. The Software User's Guide and Network User's Guide include instructions for features available when connected to a computer. (eg. Printing, scanning and networking details)



Brother Solutions Center

You can access the Brother Solutions Center which is a Web site offering information about your Brother product including FAQs, User's Guides, driver updates and tips for using your machine.



On-Line Registration

You will be pointed to the Brother Product Registration Web Page for quick registration of your machine.

STEP 2

Installing the Driver & Software

Follow the instructions on this page for your operating system and interface.
For the latest drivers and documentations and to find the best solution for your problem or question, access the Brother Solutions Center directly from the driver or visit <http://solutions.brother.com>.

Windows®



For USB Interface Users
(For Windows® 98/98SE/Me/2000 Professional/XP/XP Professional x64 Edition).... 14



For Network Interface Users (DCP-540CN only)
(For Windows® 98/98SE/Me/2000 Professional/XP/XP Professional x64 Edition).... 17

Macintosh®



For USB Interface Users
(For Mac OS® X 10.2.4 or greater) 21



For Network Interface Users (DCP-540CN only)
(For Mac OS® X 10.2.4 or greater) 24

For USB Interface Users

(For Windows® 98/98SE/Me/2000 Professional/XP/XP Professional x64 Edition)

Important

Make sure that you have finished the instructions from Step 1 *Setting Up the Machine* on pages 4 through 11.

Note

- Please close any applications running before installing MFL-Pro Suite.
- Make sure there are no memory cards in the media drive of the machine.

- 1 Unplug the machine from the AC outlet and from your computer, if you already connected an interface cable.

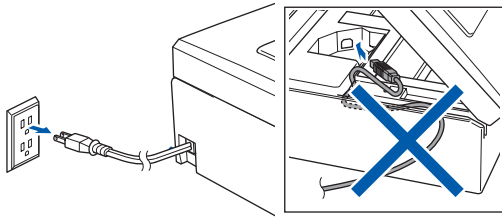

- 2 Turn on your PC.
(For Windows® 2000 Professional/XP/XP Professional x64 Edition, you must be logged on with Administrator rights.)

- 3 Put the supplied CD-ROM into your CD-ROM drive. If the model name screen appears, choose your machine. If the language screen appears, choose your language.



- 4 The CD-ROM main menu will appear. Click **Install MFL-Pro Suite**.



Note

- If this window does not appear, use Windows® Explorer to run the **setup.exe** program from the root folder of the Brother CD-ROM.
- If you are using Windows® 2000 Professional and have not installed service pack 3 (SP3) or greater:

To access the PhotoCapture Center® features from your computer you may have to install a Windows® 2000 update first.

The Windows® 2000 update is included with the MFL-Pro Suite installer.

To install the update, follow the steps below:

- 1 Click **OK** to start installation of the Windows® updates.

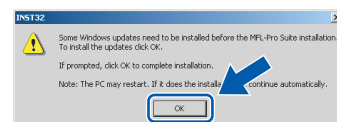

- 2 When instructed, click **OK** to restart your computer.
- 3 After the computer restarts, the installation of MFL-Pro Suite will automatically continue. If the installation does not continue automatically, open the main menu again by ejecting and then reinserting the CD-ROM disc or double-click the **setup.exe** program from the root folder, and continue from step 4 to install MFL-Pro Suite.

- 5** After reading and accepting the ScanSoft® PaperPort® SE License Agreement, click **Yes**.

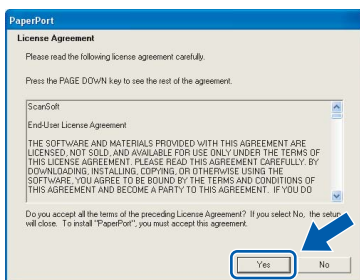

- 6** The installation of PaperPort® SE will automatically start and is followed by the installation of MFL-Pro Suite.

- 7** When the Brother MFL-Pro Suite Software License Agreement window appears, click **Yes** if you agree to the Software License Agreement.

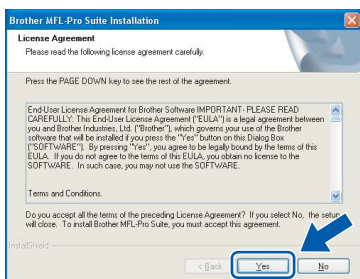

- 8** Choose **Standard (DCP-330C)** or **Local Connection (DCP-540CN)**, and then click **Next**. The installation continues.

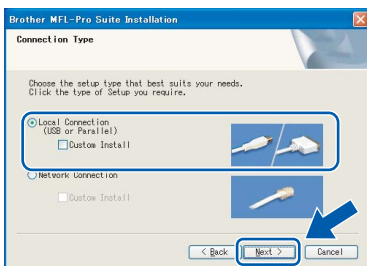
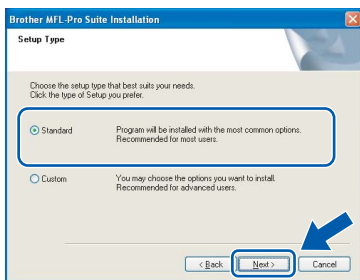

- 9** When this screen appears, go to the next step.



- 10** Using both hands, use the plastic tabs on both sides of the machine to lift the scanner cover until it locks securely into the open position.

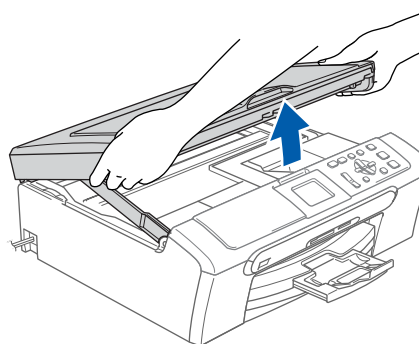

- 11** Insert the USB cable into the USB socket marked with a  symbol. You will find the USB socket inside the machine as shown below.

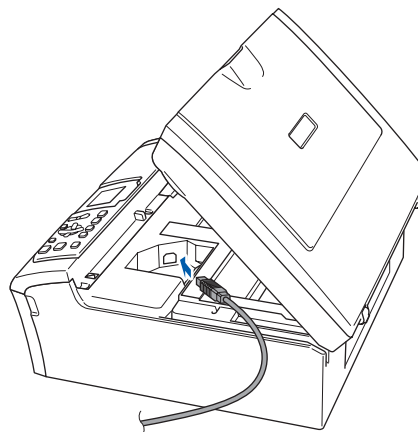

- 12** Carefully route the USB cable through the trench and out the back of the machine as shown below and connect the cable to your computer.

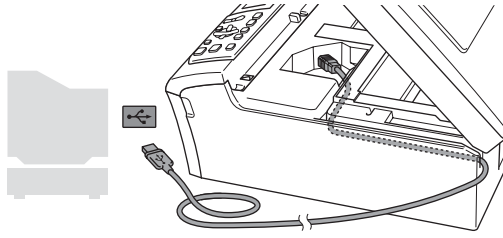

⊘ Improper Setup

- **DO NOT** connect the machine to a USB port on a keyboard or a non-powered USB hub. Brother recommends that you connect the machine directly to your computer.
- Make sure that the cable does not restrict the cover from closing, or an error may occur.

- 13** Lift the scanner cover to release the lock (1). Gently push the scanner cover support down (2) and close the scanner cover (3).

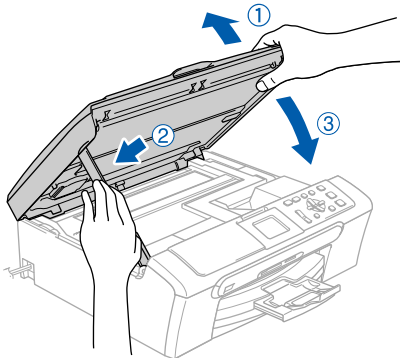

- 14** Turn on the machine by connecting the power cord.

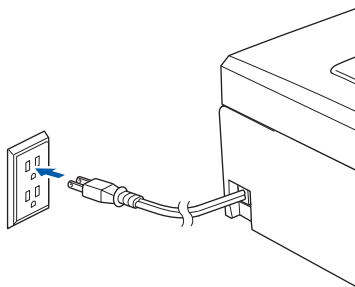

The installation of the Brother drivers will automatically start. The installation screens appear one after another. **Please wait, it will take a few seconds for all the screens to appear.**

⊘ Improper Setup

DO NOT try to cancel any of the screens during this installation.

- 15** When the On-Line Registration screen is displayed, make your selection and follow the on-screen instructions.

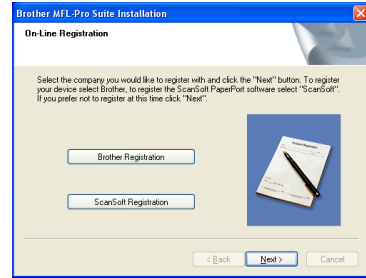

- 16** Click **Finish** to restart your computer. (After restarting the computer, for Windows® 2000 Professional/XP/XP Professional x64 Edition, you must be logged on with Administrator rights.)

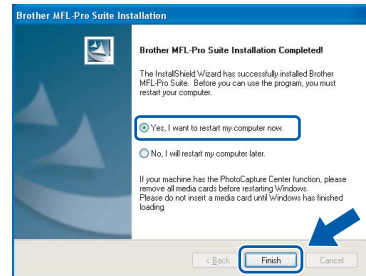

Note

After restarting the computer, the Installation Diagnostics will run automatically. If the installation is unsuccessful, the installation results window will be shown. If the Diagnostics shows a failure, please follow the on-screen instructions or read the on-line help and FAQs in **Start/All Programs (Programs)/Brother/DCP-XXXX**.



The MFL-Pro Suite has been installed and the installation is now complete.



Note

- MFL-Pro Suite includes the Printer Driver, Scanner Driver, Brother ControlCenter3, ScanSoft® PaperPort® SE with OCR and True Type® fonts. PaperPort® SE is a document management application for scanning and viewing documents.
- Windows® XP Professional x64 Edition does not support the Brother ControlCenter3 Modern user interface (see the Software User's Guide located on the CD-ROM for details).

For Network Interface Users (DCP-540CN only) (For Windows® 98/98SE/Me/2000 Professional/XP/XP Professional x64 Edition)

Important

Make sure that you have finished the instructions from Step 1 *Setting Up the Machine* on pages 4 through 11.

- 1 Unplug the machine from the AC outlet.
- 2 Using both hands, use the plastic tabs on both sides of the machine to lift the scanner cover until it locks securely into the open position.

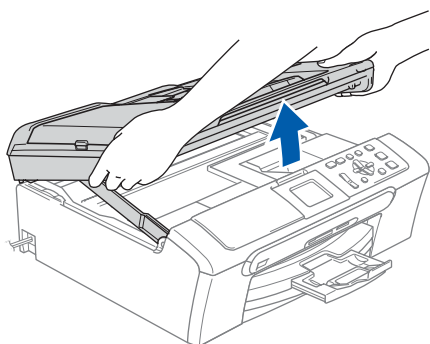

- 3 Insert the network cable into the LAN socket marked with a  symbol. You will find the LAN socket inside the machine on the left as shown below.

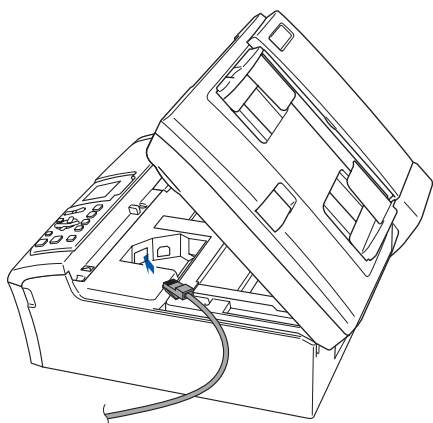

- 4 Carefully route the network cable through the trench and out the back of the machine as shown below. Then, connect the cable to your network.

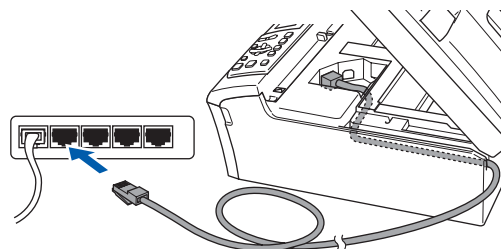

⊘ Improper Setup

Make sure that the cable does not restrict the cover from closing, or an error may occur.

📝 Note

If both USB and LAN cables are being used, guide both cables through the trench with one on top of the other.

- 5 Lift the scanner cover to release the lock (①). Gently push the scanner cover support down (②) and close the scanner cover (③).

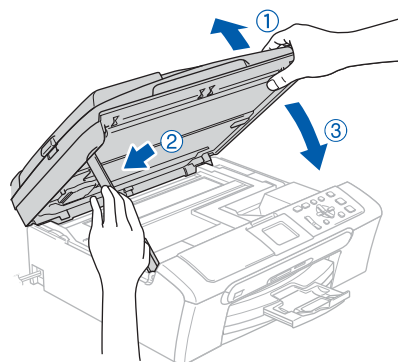

- 6 Turn on the machine by connecting the power cord.

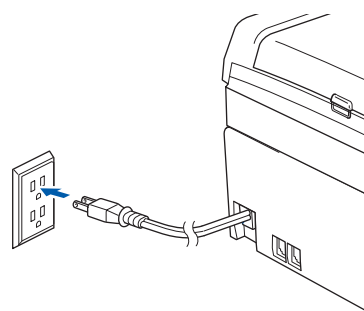

7 Turn on your computer.
(For Windows® 2000 Professional/XP/XP Professional x64 Edition, you must be logged on with Administrator rights.)
Close any applications running before installing the MFL-Pro Suite.



Note

Before installation, if you are using Personal Firewall software, disable it.

8 Put the supplied CD-ROM into your CD-ROM drive. If the model name screen appears, choose your machine. If the language screen appears, choose your language.



9 The CD-ROM main menu will appear. Click **Install MFL-Pro Suite**.



Note

- If this window does not appear, use Windows® Explorer to run the **setup.exe** program from the root folder of the Brother CD-ROM.
- If you see the following screen, click **OK** to install the Windows® updates. After the updates are installed your PC may restart. Then the installation will automatically continue.

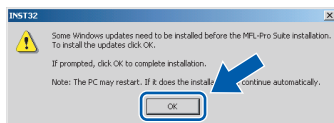

*If the installation does not continue automatically, open the main menu again by ejecting then reinserting the CD-ROM disc or double-click the **setup.exe** program from the root folder, and continue from step 9 to install MFL-Pro Suite.*

10 After reading and accepting the ScanSoft® PaperPort® SE License Agreement, click **Yes**.

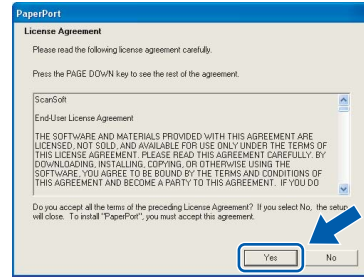

11 The installation of PaperPort® SE will automatically start and is followed by the installation of MFL-Pro Suite.

12 When the Brother MFL-Pro Suite Software License Agreement window appears, click **Yes** if you agree to the Software License Agreement.

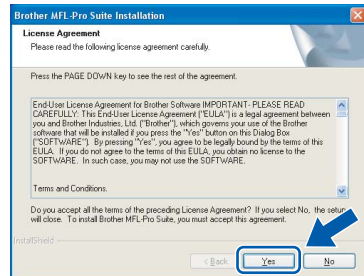

13 Choose **Network Connection**, and then click **Next**.

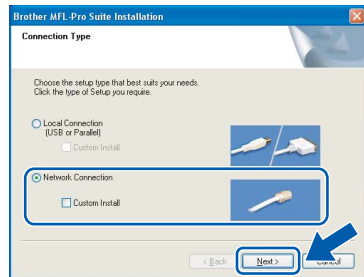

14 The installation of the Brother drivers will automatically start. The installation screens appear one after another. **Please wait, it will take a few seconds for all the screens to appear.**

⊘ Improper Setup

DO NOT try to cancel any of the screens during this installation.

- 15** If the machine is configured for your network, choose the machine from the list, and then click **Next**.

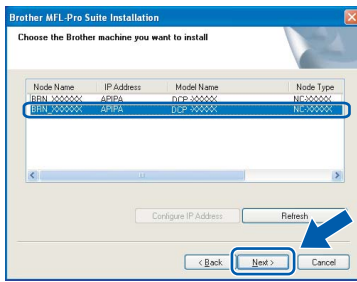

- Note** This window will not appear if there is only one machine connected on the network, it will be chosen automatically.

- 16** If the machine is not yet configured for use on your network, the following screen appears.



Click **OK**. The **Configure IP Address** window will appear. Enter an IP address for your machine that is suitable for your network by following the on-screen instructions.

- 17** When the Brother and ScanSoft On-Line Registration screen is displayed, make your selection and follow the on-screen instructions.

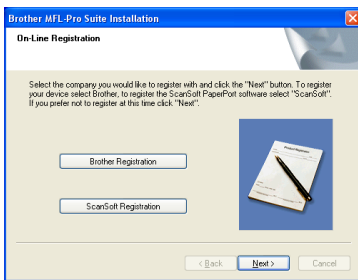

- 18** Click **Finish** to restart your computer. (For Windows® 2000 Professional/XP/XP Professional x64 Edition, you must be logged on with Administrator rights.)

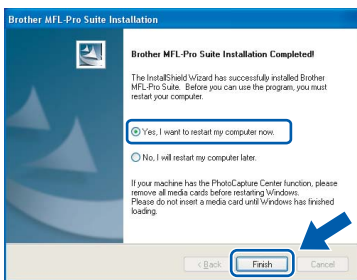

Note

- After restarting the computer, the *Installation Diagnostics* will run automatically. If the installation is unsuccessful, the installation results window will be shown. If the *Diagnostics* shows a failure, please follow the on-screen instructions or read the on-line help and FAQs in **Start/All Programs (Programs)/Brother/DCP-XXXX**.
- Once you are sure that you can print after the installation, restart your *Firewall* software.
- Firewall settings on your PC may reject the necessary network connection for *Network Scanning*. Follow the instructions below to configure your *Windows Firewall*. If you are using a personal *Firewall* software, see the *User's Guide* for your software or contact the software manufacturer.
- **For Windows® XP SP2 users:**
 - 1 Click the **Start** button, **Control Panel** and then **Windows Firewall**. Make sure that *Windows Firewall* on the **General** tab is set to **On**.
 - 2 Click the **Advanced** tab and **Settings...** button.

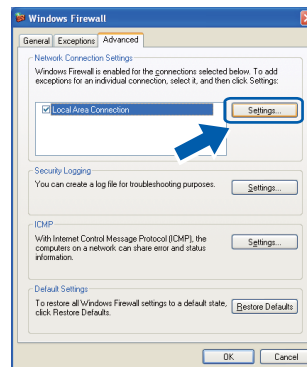

- 3 Click the **Add** button.
- 4 Add port 54925 for network scanning, enter the information below:
 - 1) (Any description)
 - 2) Localhost
 - 3) 54925
 - 4) 54925
 - 5) Select **UDP**
 Then, click **OK**.

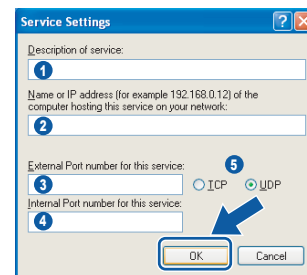

- 5 Click the **Add** button.

- 6 Add port 137 for network scanning, enter the information below:
 - 1) (Any description)
 - 2) Localhost
 - 3) 137
 - 4) 137
 - 5) Select **UDP**Then, click **OK**.
 - 7 Make sure if the new settings are added and are checked, and then click **OK**.
-



The MFL-Pro Suite has been installed and the installation is now complete.



Note

- *MFL-Pro Suite includes the Network Printer Driver, Network Scanner Driver, Brother ControlCenter3, ScanSoft® PaperPort® SE with OCR and True Type® fonts.*
PaperPort® SE is a document management application for scanning and viewing documents.
 - *Windows® XP Professional x64 Edition does not support the Brother ControlCenter3 Modern user interface (see the Software User's Guide located on the CD-ROM for details).*
-

For USB Interface Users (For Mac OS® X 10.2.4 or greater)

Important

Make sure that you have finished the instructions from Step 1 *Setting Up the Machine* on pages 4 through 11.

Note

For Mac OS® X 10.2.0 to 10.2.3 users, upgrade to Mac OS® X 10.2.4 or greater. (For the latest information for Mac OS® X, visit <http://solutions.brother.com>)

- Using both hands, use the plastic tabs on both sides of the machine to lift the scanner cover until it locks securely into the open position.

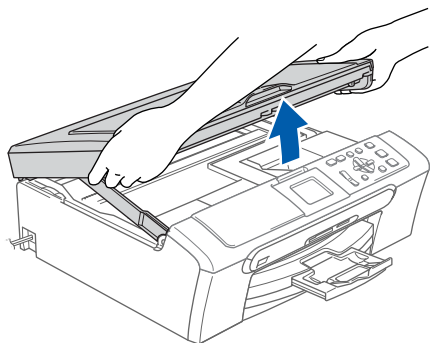

- Insert the USB cable into the USB socket marked with a  symbol. You will find the USB socket inside the machine as shown below.

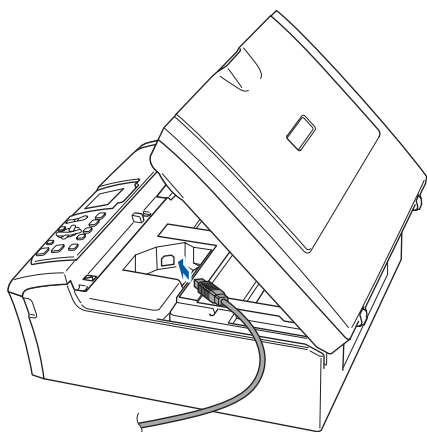

- Carefully route the USB cable through the trench and out the back of the machine as shown below and connect the cable to your computer.

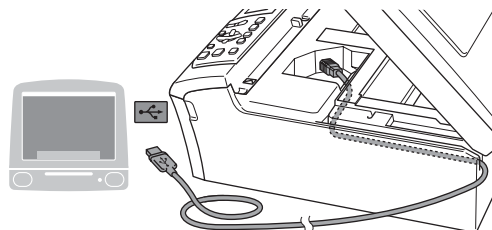

⊘ Improper Setup

- DO NOT connect the machine to a USB port on a keyboard or a non-powered USB hub. Brother recommends that you connect the machine directly to your computer.
- Make sure that the cable does not restrict the cover from closing, or an error may occur.

- Lift the scanner cover to release the lock (①). Gently push the scanner cover support down (②) and close the scanner cover (③).

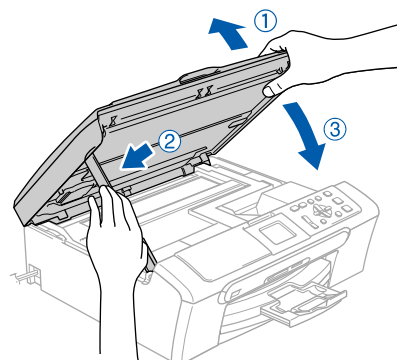

- Turn on the machine by connecting the power cord.

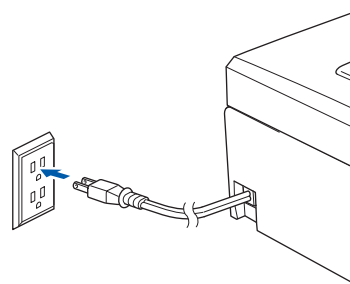

- 6 Turn on your Macintosh®.
- 7 Put the supplied CD-ROM into your CD-ROM drive.



- 8 Double-click the **Start Here OSX** icon to install. Follow the on-screen instructions.

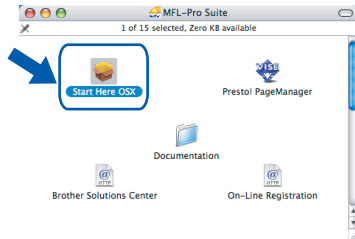

Note

*Please wait, it will take a few seconds for the software to install. After the installation, click **Restart** to finish installing the software.*

- 9 The Brother software will search for the Brother device. During this time the following screen will appear.

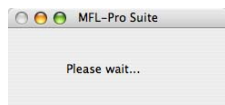

- 10 When this screen appears, click **OK**.

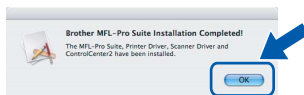

For Mac OS® X 10.3.x or greater users:
The MFL-Pro Suite, Brother printer driver, scanner driver and Brother ControlCenter2 have been installed and the installation is now complete.
Go to step 15.

- 11 For Mac OS® X 10.2.4 to 10.2.8 users:
 Click **Add**.

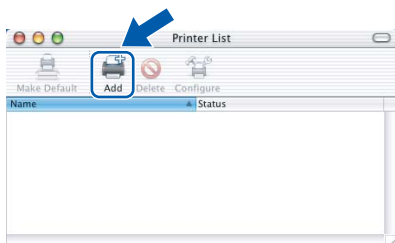

- 12 Choose **USB**.

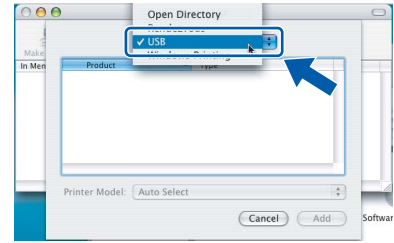

- 13 Choose **DCP-XXXX** (where XXXX is your model name), and then click **Add**.

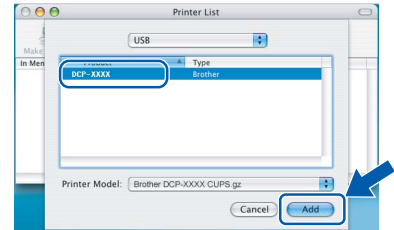

- 14 Click **Print Center**, then **Quit Print Center**.

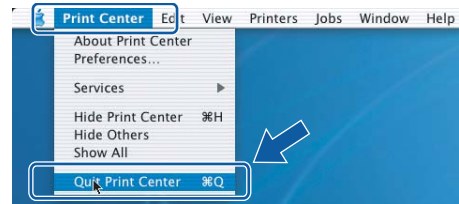
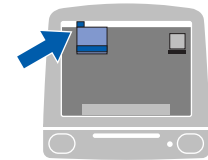

The MFL-Pro Suite, Brother printer driver, scanner driver and Brother ControlCenter2 have been installed and the installation is now complete.

- 15** To install Presto!® PageManager®, click the **Presto! PageManager** icon and follow the on-screen instructions.

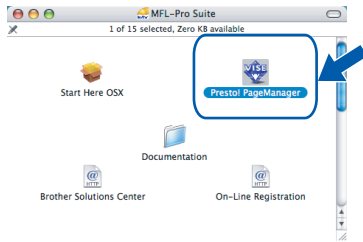

Note

When Presto!® PageManager® is installed OCR capability is added to the Brother ControlCenter2. You can easily scan, share and organize photos and documents using Presto!® PageManager®.



Presto!® PageManager® has been installed and the installation is now complete.

For Network Interface Users (DCP-540CN only) (For Mac OS® X 10.2.4 or greater)

Important

Make sure that you have finished the instructions from Step 1 *Setting Up the Machine* on pages 4 through 11.

- Using both hands, use the plastic tabs on both sides of the machine to lift the scanner cover until it locks securely into the open position.

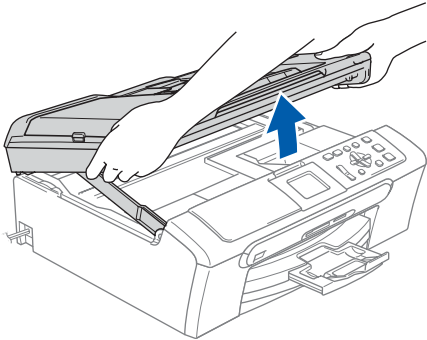

- Insert the network cable into the LAN socket marked with a  symbol. You will find the LAN socket inside the machine on the left as shown below.

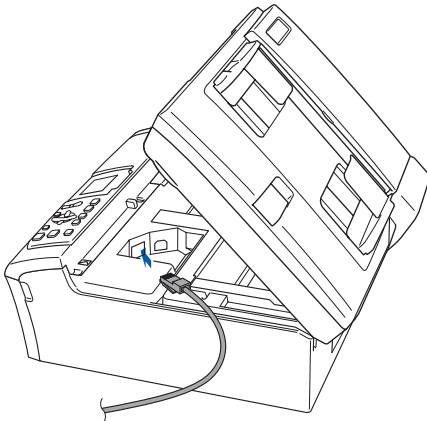

- Carefully route the network cable through the trench and out the back of the machine as shown below. Then, connect the cable to your network.

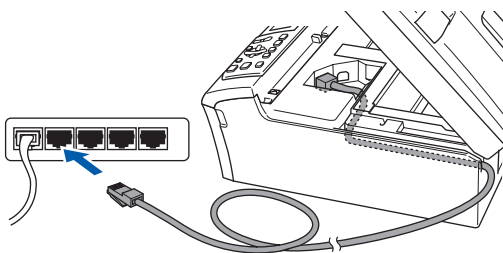

⊘ Improper Setup

Make sure that the cable does not restrict the cover from closing, or an error may occur.

Note

If both USB and LAN cables are being used, guide both cables through the trench with one on top of the other.

- Lift the scanner cover to release the lock (①). Gently push the scanner cover support down (②) and close the scanner cover (③).

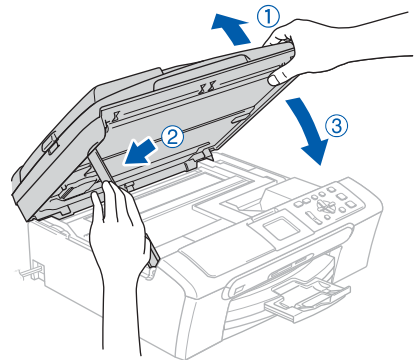

- Turn on the machine by connecting the power cord.

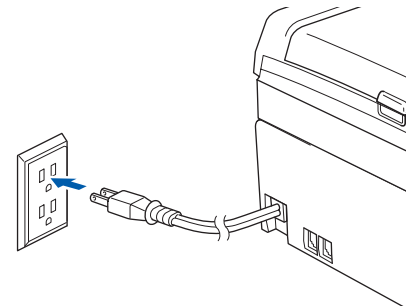

- Turn on your Macintosh®.
- Put the supplied CD-ROM into your CD-ROM drive.



- 8** Double-click the **Start Here OSX** icon to install. Follow the on-screen instructions.

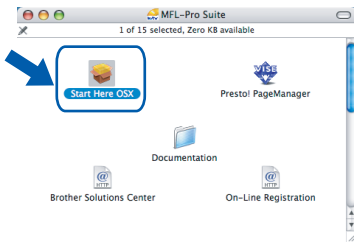

Please wait, it will take a few seconds for the software to install. After the installation, click **Restart** to finish installing the software.

- 9** The Brother software will search for the Brother device. During this time the following screen will appear.

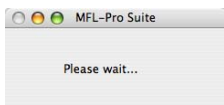

Note

- If the machine is configured for your network, choose the machine from the list, and then click **OK**. This window will not appear if there is only one machine connected on the network, it will be chosen automatically. Go to step 10.

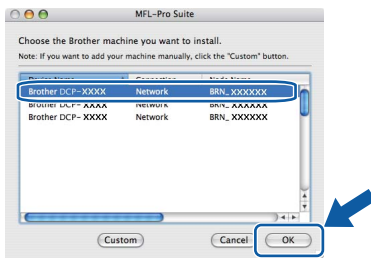

- If this screen appears click **OK**.



- Enter a name for your Macintosh® in **Display Name** up to 15 characters long and click **OK**. Go to step 10.

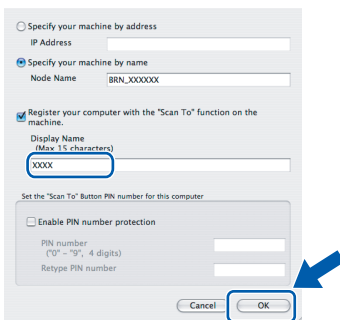

- If you want to use the machine's Scan key to scan over the network you must check the **Register your computer with the "Scan To" function on the machine box**.

- The name you enter will appear on the machine's LCD when you press the **Scan** key and choose a scan option. (For more information, see *Network Scanning in the Software User's Guide on the CD-ROM*.)

- 10** Click **Add**.

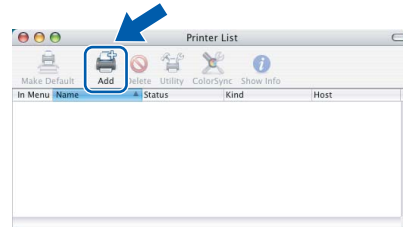

Note

For Mac OS® X 10.4 users, go to step 13.

- 11** For Mac OS® X 10.2.4 to 10.3.x users: Make the selection shown below.

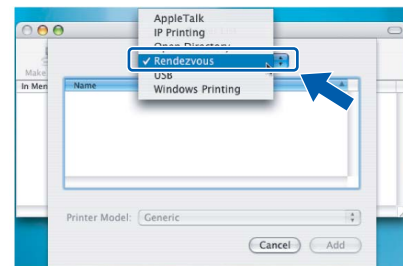

- 12** Choose **DCP-XXXX** (where XXXX is your model name), and then click **Add**. Go to step 14.

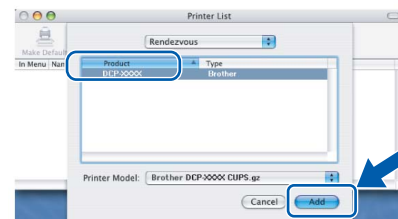

- 13** For Mac OS® X 10.4 users: Choose **DCP-XXXX** (where XXXX is your model name), and then click **Add**.

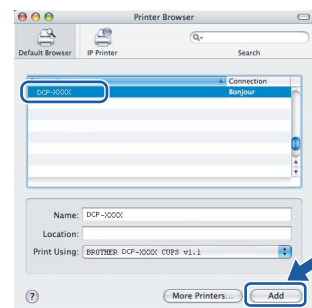

- 14** Click **Printer Setup Utility**, then **Quit Printer Setup Utility**.

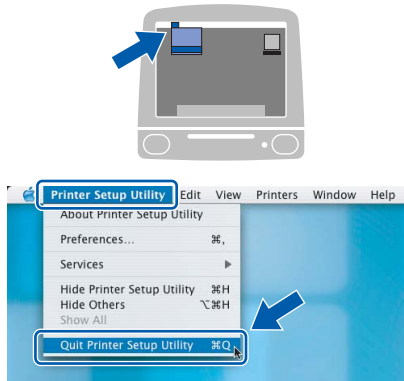
**Note**

For Mac OS® X 10.2.x users, click **Print Center**, then **Quit Print Center**.



The **MFL-Pro Suite**, **Brother printer driver**, **scanner driver** and **Brother ControlCenter2** have been installed and the installation is now complete.

- 15** To install Presto!® PageManager®, click the **Presto! PageManager** icon and follow the on-screen instructions.

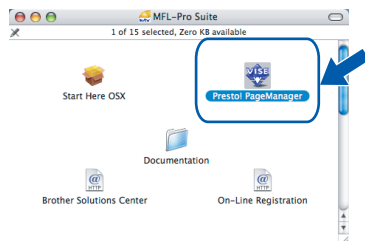
**Note**

When **Presto!® PageManager®** is installed **OCR** capability is added to the **Brother ControlCenter2**. You can easily scan, share and organize photos and documents using **Presto!® PageManager®**.



Presto!® PageManager® has been installed and the installation is now complete.

BRAdmin Professional configuration utility (For Windows[®] users)

The BRAdmin Professional utility for Windows[®] is designed to manage your Brother network connected devices such as network-ready Multifunction devices and/or network-ready printers in a Local Area Network (LAN) environment. For more information on BRAdmin Professional, visit us at <http://solutions.brother.com>.

Installing the BRAdmin Professional configuration utility

- 1 Put the supplied CD-ROM into your CD-ROM drive. The opening screen will appear automatically. Follow the on-screen instructions.



- 2 Click **Install Other Drivers or Utilities** on the menu screen.

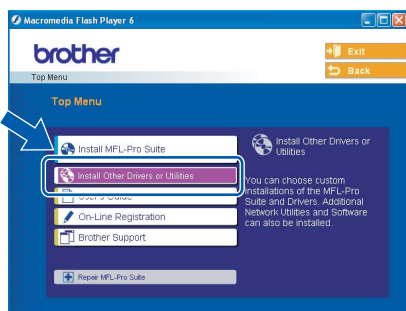

- 3 Click **BRAdmin Professional** and follow the on-screen instructions.

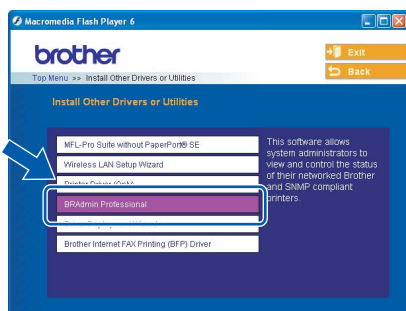

Setting your IP address, Subnet Mask and Gateway using BRAdmin Professional

- 1 Start BRAdmin Professional, and choose **TCP/IP**.

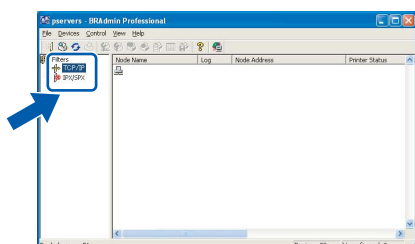

- 2 Click **Devices**, then **Search Active Devices**. BRAdmin searches for new devices automatically.

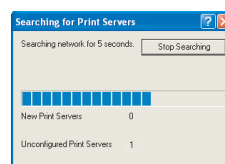
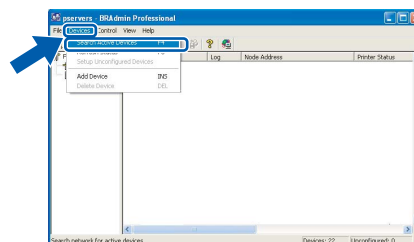

- 3 Double-click the new device.

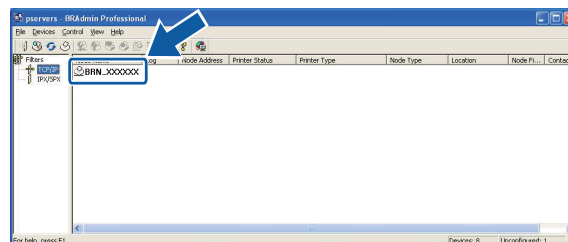

- 4 Enter the **IP Address**, **Subnet Mask** and **Gateway**, and then click **OK**.

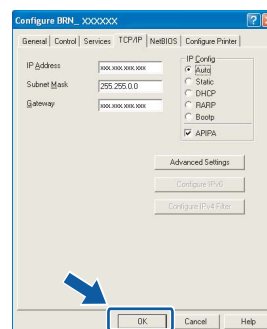

- 5 The address information will be saved to the machine.

Note

You can use the BRAdmin Professional utility to set a password. (See the Network User's Guide on the CD-ROM.)

BRAdmin Light configuration utility (For Mac OS® X users)

The Brother BRAdmin Light software is a Java™ application that is designed for the Apple Mac OS® X environment. It supports some of the features of the Windows BRAdmin Professional software. For example, using the BRAdmin Light software, you can change some network settings on Brother's network ready printers and multifunction devices.

The BRAdmin Light software will be installed automatically when you install the MFL-Pro Suite. Please refer to installing the driver and software in this Quick Setup Guide if you have not yet installed the MFL-Pro Suite. For more information on BRAdmin Light, visit us at <http://solutions.brother.com>.

Setting your IP address, Subnet Mask and Gateway using BRAdmin Light

Note

If you have a DHCP/BOOTP/RARP server in your network, you don't have to do the following operation. The print server will automatically obtain its own IP address. Make sure that version 1.4.1_07 or later of Java™ client software is installed on your computer.

- 1 Double-click the **Macintosh HD** icon on your desktop.



- 2 Choose **Library**, **Printers**, **Brother** and then **Utilities**.

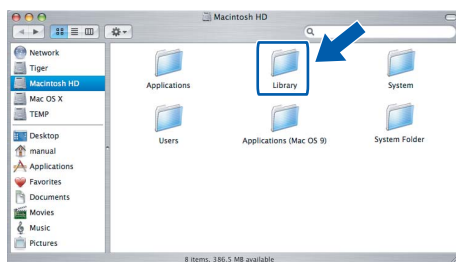

- 3 Double-click the **BRAdmin Light.jar** file. Run the BRAdmin Light software. BRAdmin Light searches for new devices automatically.

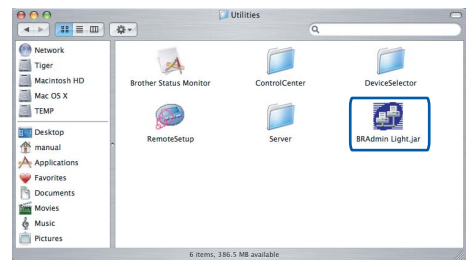

- 4 Double-click the new device.

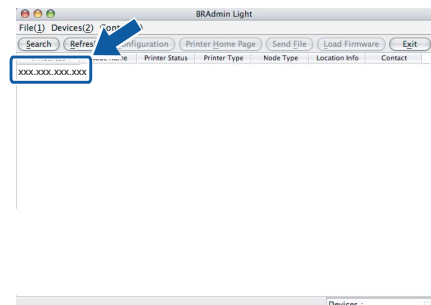

- 5 Enter the **IP Address**, **Subnet Mask** and **Gateway**, and then click **OK**.

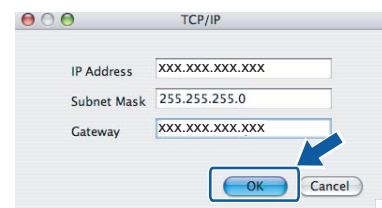

- 6 The address information will be saved to the machine.

Replacement consumables

When the time comes to replace ink cartridges, an error message will be indicated on the LCD. For more information about the ink cartridges for your machine, visit <http://solutions.brother.com> or contact your local Brother re-seller.

Ink cartridge

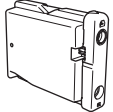
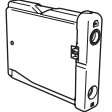
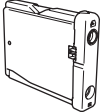
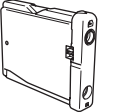
Black	Yellow	Cyan	Magenta
LC51BK	LC51Y	LC51C	LC51M
			

Trademarks

The Brother logo is a registered trademark of Brother Industries, Ltd.

Brother is a registered trademark of Brother Industries, Ltd.

Multi-Function Link is a registered trademark of Brother International Corporation.

Windows and Microsoft are registered trademarks of Microsoft in the U.S. and other countries.

Macintosh and True Type are registered trademarks of Apple Computer, Inc.

PaperPort is a registered trademark of ScanSoft, Inc.

Presto! PageManager is a registered trademark of NewSoft Technology Corporation.

PictBridge is a trademark.

Each company whose software title is mentioned in this manual has a Software License Agreement specific to its proprietary programs.

All other brand and product names mentioned in this manual are trademarks or registered trademarks of their respective companies.

Compilation and Publication

Under the supervision of Brother Industries Ltd., this manual has been compiled and published, covering the latest product descriptions and specifications.

The contents of this manual and the specifications of this product are subject to change without notice.

Brother reserves the right to make changes without notice in the specifications and materials contained herein and shall not be responsible for any damages (including consequential) caused by reliance on the materials presented, including but not limited to typographical and other errors relating to the publication.

This product is designed for use in a Professional Environment.

Copyright and License

©2006 Brother Industries, Ltd.

This product includes software developed by the following vendors.

©1998-2006 TROY Group, Inc.

©1983-2006 PACIFIC SOFTWARES, INC.

brother®



LP3935001①

US/CAN

Printed in China